

(MUST BE COMPLETED FOR EACH ZONED LOCATION)

OAC

MAY 22 2019

Name of Applicant: Big Time Billboards

Location of Property: See attached exhibit "A"  
(Location description must coincide with description given on the application form.)

In the Corporate Limits of: Chandler  
(If not inside the corporate limits of any town or city Please enter none.)

Rezoned 2 months ago  
Planning

▶ The remainder of this form must be completed by the proper zoning authority. ◀

1. What is the zoning designation of the above-referenced property?  
C-2
2. Does your city/county have a comprehensive zoning/development plan? (An official plan or map which outlines the intended use of properties located inside of your jurisdiction.)  Yes  No
3. If yes, does the above-referenced property's zoning designation meet with the plan guidelines?  Yes  No
4. Was this zoning designated within the last two years?  Yes  No  
(If yes, a copy of the zoning application and the approved documentation must be attached.)

Rezoned 1-3-19 by Mapping Dept

Russell Holland  
Name of Authority (City, County etc.) CITY OF CHANDLER  
Telephone No. (405) 258-3200

RUSSELL HOLLAND  
Printed Name of Zoning Official MAPPING DEPT.  
Title

Russell Holland  
Signature of Zoning Official 9-24-13  
Date

Chandler OK, Lon

\*If the zoning designation is PUD, SPUD or Corridor, a copy of the approved plan must be submitted with application.

(Notice: Completion of this form does not constitute official permission or clearance from any local government - this form is solely for the purpose of zoning verification to be used by the Oklahoma Department of Transportation.)

Form OAC 1-504 I spoke with Russell Holland, he thought the property he saw. The SOA was for a different property.

Entered into Public Hearing at 5:26 p.m.

John Webster was present and informed the council that the main reason for the change is so that Stokley's can lease the property and put up billboard signs for advertising. Property has to be zoned commercial. Planning Commission approved the request to rezone on Monday, December 10, 2018.

Public hearing closed at 5:31 p.m.

- VIII. **Consideration, Discussion and Possible Action on Public Hearing** - Motion was made by Temple, seconded by Evans to approve the zoning request. Temple-yea, Evans-yea, Fowble-yea, and Imel-yea. Motion carried.
- IX. **Consideration, Discussion and Possible Action on Budget Amendment for the Airport in the Amount of \$58,608.00 Derived from the FAA Grant** - Motion was made by Evans, seconded by Temple to approve the budget amendment as presented. Evans-yea, Temple-yea, Fowble-yea, and Imel-yea. Motion carried.
- X. **Consideration, Discussion and Possible Action on Budget Amendment for the Fire Department in the amount on \$10,000.00 Derived from the TransCanada Charitable Foundation Grant** - Motion was made by Fowble, seconded by Evans, to approve the budget amendment as presented. Fowble-yea, Evans-yea, Temple-yea, and Imel-yea. Motion carried.
- XI. **Consideration, Discussion and Possible Action on Budget Amendment for the Fire Department in the amount of \$825.00 Derived from Plains Marketing Grant** - Motion was made by Evans, seconded by Temple to approve the budget amendment as presented. Evans-yea, Temple-yea, Fowble-yea, and Imel-yea. Motion carried.
- XII. **Consideration, Discussion and Possible Action on Approving Ordinance 2019-01 Rezoning Property Located at 417 Manvel Ave** - Motion was made by Evans, seconded by Temple to approve Ordinance 2019-01. Evans-yea, Temple-yea, Fowble-yea, and Imel-yea. Motion carried.
- XIII. **Consideration, Discussion and Possible Action on Declaring Ordinance 2019-01 an Emergency** - Motion was made by Evans, seconded by Temple declaring Ordinance 2019-01 an emergency. Evans-yea, Temple-yea, Fowble-yea, and Imel-yea. Motion carried.
- XIV. **Consideration, Discussion and Possible Action on Approving Resolution 2019-01 Notice of Election for Mayor, Wards II and IV** - Motion was made by Fowble, seconded by Evans on approving Resolution 2019-01. Fowble-yea, Evans-yea, Temple-yea, and Imel-yea. Motion carried.
- XV. **New Business** - None
- XVI. **Adjourn** - Motion was made by Evans, seconded by Temple to adjourn. Evans-yea, Temple-yea, Fowble-yea, and Imel-yea. Motion carried. The Chandler City Council meeting adjourned at 5:42 p.m.

REZONING OF JOHN & KAREN WEBSTER PROPERTY

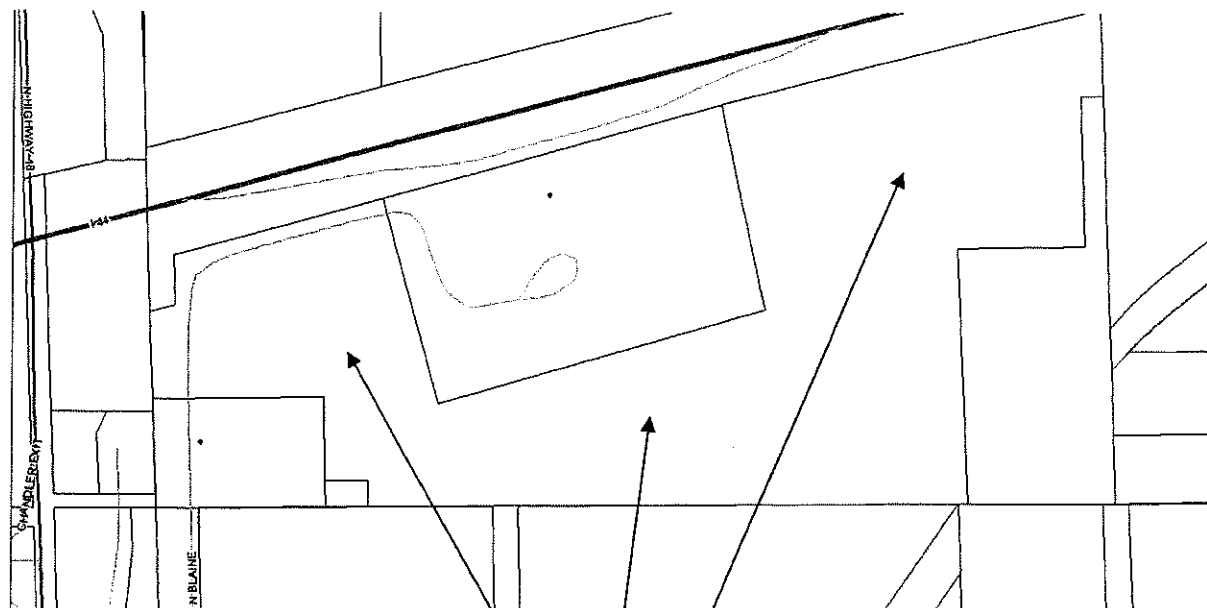

SITE LOCATION

Stokely Signs ⇒ Billboard signs

- Matthew Radcliff - Present - Yes
- Barry Lewis - Present - Yes
- Alma Zene - Absent
- David Burgess - Present - Yes
- Vivian Sage - Yes