



Creek

Data provided by JaNell Enlow County Assessor

Property Information - Date 06/26/2022

The Creek County Assessor's Office has made every effort to insure the accuracy of the data contained on this web site; however this material may be slightly dated which could have an impact on its accuracy.

The information must be accepted and used by the recipient with the understanding that the data was developed and collected only for the purpose of establishing fair market value for ad valorem taxation. Although changes may be made periodically to the tax laws, administrative rules and similar directives, these changes may not always be incorporated in the material on this web site.

The Creek County Assessor's Office assumes no liability for any damages incurred, whether directly or indirectly, incidental, punitive or consequential, as a result of any errors, omissions or discrepancies in any information published on this web site or by any use of this web site.

Assessment Data			Primary Image						
Account	190015220								
Parcel ID	0000-26-018-011-0-037-00								
Cadastral ID	0000-018-011-26-0-037-00								
Property Type	REAL - Real Property								
Property Class	RC								
Tax Area	12 - Sapulpa Rural								
Lot Size	48.93 - Acres								
Owners Name	INTERNATIONAL METAL INC % REAL ALLOY % GREG FLAWSGARTEN 3700 PARK EAST DRIVE SUITE 300 BEACHWOOD OH 44122-0000								
Parcel Location							Image Date	2/19/2020	
Situs	01508 N EIGHTH ST								
Subdivision									
Lot/Block	/								
Sec/Twn/Rng	26 - 18N - 11E - 0								
Neighborhood	600 - COMMERCIAL								
Legal Description									
26-18-11 NW NE & ALL SW NE N TP & BEG NE COR NW S01'18 E242 S88'06 53.47 W78 N01'18 W242 N88'08 53.47 E78.01 POB & BEG SE COR NE NW N230 W305 S20 W245 S210 E550 POB 48.93 AC BK 29 PG 1456 BK 29 PG 1134 & BK 40 PG 1523 BK 723 PG 1197-1299 (ALERIS RECYCLING INC)									
Valuation	2022	2021	Tax Detail (Millages)		%	Mills	Dollars		
Land Value	736,507	736,507	C001	Creek County					
Improvements	2,129,208	2,006,372		County General Fund	10.1	10.26	3,384.48		
Mobile Home	0	0		Health Fund	2.5	2.57	847.77		
Fair Market Value	2,865,715	2,742,879		Common Fund	4.0	4.10	1,352.47		
Taxable Value - Capped	2,748,953	2,618,051	SI33	Sapulpa School I-33					
Assesment Ratio	12%	12%		School General Fund	35.2	35.78	11,802.79		
Gross Assessed	329,875	314,166		School Building Fund	5.0	5.11	1,685.64		
Exemptions	0	0		School Sinking Fund	27.1	27.61	9,107.75		
Net Assessed	329,875	314,166	E001	Creek County Ambulance					
Tax Rate	101.7700	101.7700		General Fund	3.0	3.08	1,016.00		
Estimated Taxes	33,571.00	31,973.00	V001	Vo-Tech 1					
				General Fund	10.1	10.26	3,384.48		
				Building Fund	2.9	3.00	989.61		



Creek

Data provided by JaNell Enlow County Assessor

Property Information - Date 06/26/2022

Sale History

Instrument	Book	Page	Grantor	Date	Price	Code
------------	------	------	---------	------	-------	------

Billed History

Tax Year	Billed Owner	Tax Area	Total Value	Exemptions	Taxable Value	Billed Tax
2021	INTERNATIONAL METAL INC	12	2,742,879	0	314,166	31,973.00
2020	INTERNATIONAL METAL INC	12	2,710,258	0	299,206	30,797.00
2019	INTERNATIONAL METAL INC	12	2,374,650	0	284,958	29,901.00
2018	INTERNATIONAL METAL INC	12	2,265,305	0	271,837	28,997.00
2017	INTERNATIONAL METAL INC	12	2,265,305	0	271,837	29,068.00
2016	INTERNATIONAL METAL INC	12	2,265,305	0	271,837	27,064.00
2015	INTERNATIONAL METAL INC	12	2,265,305	0	271,837	27,330.00
2014	INTERNATIONAL METAL INC	12	2,265,305	0	271,837	27,706.00
2013	INTERNATIONAL METAL INC	12	2,265,305	0	271,837	27,420.00
2012	INTERNATIONAL METAL INC	12	2,727,364	0	327,284	32,565.00
2011	INTERNATIONAL METAL INC	12	2,732,744	0	327,930	33,042.00
2010	INTERNATIONAL METAL INC	12	2,755,133	0	330,616	33,660.00
2009	INTERNATIONAL METAL INC	12	2,755,133	0	330,616	34,222.00

Commercial Improvements

Card	Improvement Type	Condition	Quality	Year	Exterior Wall	HVAC	Stories	Total Area
1	100% Office Building (344)	Average	Average	1975	Stud Rubble Stone Veneer	Forced Air Unit	2.00	5,764

Outbuildings

Bldg	Improvement Type	Condition	Quality	Year	Exterior Wall	Roof	Dimensions	Total Area
1	FLAT VALUE UNDERGROUND WIRING	Average	Average	1998			0x0x0	7,873
2	AWNG, METAL/DIRT (WITH STEEL BEAMS)	Average	Average	2000			80x50x0	4,000
3	Commercial Lights (mtl halide)	Average	Average	2007			0x0x0	15
4	FENCE:COMM.CHAIN-LK	Average	Average	2002			0x0x0	5,726
5	GATE, ELECTRIC	Average	Average	2007			0x0x0	1
6	Light Pole, Steel	Average	Average	2007			0x0x0	450
7	TOOL SHED/SLAB	Average	Average	1976			20x20x0	400
8	CB ELEC BLDG	Average	Average	1981			16x8x0	128
1	SLAB	Average	Average	1976			30x17x0	510
1	FLAT VALUE SCRAP BIN	Average	Average	1981			92x61x0	5,612



Creek

Data provided by JaNell Enlow County Assessor

Property Information - Date 06/26/2022

2	FLAT VALUE NORTH ALUM BIN	Average	Average	1981		232x50x0	11,600
3	FLAT VALUE WEST SCRAP BIN	Average	Average	1981		94x61x0	5,734
1	Commercial Concrete Paving	Average	Average	1975		102x35x0	3,570
2	Awning, Over Slab	Average	Average	1970		84x10x0	840
1	0			0	0 0	0x0x0	1,170
1	0			0	0 0	0x0x0	364

Attached Images

Image ID 211983
Image Date 2/19/2020



1

Image ID 211984
Image Date 2/19/2020



10

Image ID 211985
Image Date 2/19/2020



11

Image ID 211986
Image Date 2/19/2020



12



Creek

Data provided by JaNell Enlow County Assessor

Property Information - Date 06/26/2022

Attached Images

Image ID 211987
Image Date 2/19/2020



13

Image ID 211988
Image Date 2/19/2020



14

Image ID 211989
Image Date 2/19/2020



16

Image ID 211990
Image Date 2/19/2020



17



Creek

Data provided by JaNell Enlow County Assessor

Property Information - Date 06/26/2022

Attached Images

Image ID 211991
Image Date 2/19/2020



18

Image ID 211992
Image Date 2/19/2020



19

Image ID 211993
Image Date 2/19/2020



2

Image ID 211994
Image Date 2/19/2020



20



Creek

Data provided by JaNell Enlow County Assessor

Property Information - Date 06/26/2022

Attached Images

Image ID 211995
Image Date 2/19/2020



21

Image ID 211996
Image Date 2/19/2020



22

Image ID 211997
Image Date 2/19/2020



23

Image ID 211998
Image Date 2/19/2020



24



Creek

Data provided by JaNell Enlow County Assessor

Property Information - Date 06/26/2022

Attached Images

Image ID 211999
Image Date 2/19/2020



25

Image ID 212000
Image Date 2/19/2020



26

Image ID 212001
Image Date 2/19/2020



27

Image ID 212002
Image Date 2/19/2020



3



Creek

Data provided by JaNell Enlow County Assessor

Property Information - Date 06/26/2022

Attached Images

Image ID 212003
Image Date 2/19/2020



4

Image ID 212004
Image Date 2/19/2020



5

Image ID 212005
Image Date 2/19/2020



6

Image ID 212006
Image Date 2/19/2020



7



Creek

Data provided by JaNell Enlow County Assessor

Property Information - Date 06/26/2022

Attached Images

Image ID 212007
Image Date 2/19/2020



8

Image ID 212008
Image Date 2/19/2020



9

Image ID 212010
Image Date 2/19/2020



15

Image ID 116928
Image Date 11/10/2015



C:\Users\wkst-44\Pictures\2015-11-10 BYRON 11-10
15\BYRON 11-10-15 035.JPG



Creek

Data provided by JaNell Enlow County Assessor

Property Information - Date 06/26/2022

Attached Images

Image ID 116929
Image Date 11/10/2015



C:\Users\wkst-44\Pictures\2015-11-10 BYRON 11-10
15\BYRON 11-10-15 036.JPG

Image ID 116930
Image Date 11/10/2015



C:\Users\wkst-44\Pictures\2015-11-10 BYRON 11-10
15\BYRON 11-10-15 037.JPG

Image ID 116931
Image Date 11/10/2015



C:\Users\wkst-44\Pictures\2015-11-10 BYRON 11-10
15\BYRON 11-10-15 038.JPG

Image ID 116932
Image Date 11/10/2015



C:\Users\wkst-44\Pictures\2015-11-10 BYRON 11-10
15\BYRON 11-10-15 039.JPG



Creek

Data provided by JaNell Enlow County Assessor

Property Information - Date 06/26/2022

Attached Images

Image ID 116933
Image Date 11/10/2015



C:\Users\wkst-44\Pictures\2015-11-10 BYRON 11-10
15\BYRON 11-10-15 040.JPG

Image ID 116934
Image Date 11/10/2015



C:\Users\wkst-44\Pictures\2015-11-10 BYRON 11-10
15\BYRON 11-10-15 041.JPG

Image ID 116935
Image Date 11/10/2015



C:\Users\wkst-44\Pictures\2015-11-10 BYRON 11-10
15\BYRON 11-10-15 042.JPG

Image ID 116936
Image Date 11/10/2015



C:\Users\wkst-44\Pictures\2015-11-10 BYRON 11-10
15\BYRON 11-10-15 043.JPG



Creek

Data provided by JaNell Enlow County Assessor

Property Information - Date 06/26/2022

Attached Images

Image ID 116937
Image Date 11/10/2015



C:\Users\wkst-44\Pictures\2015-11-10 BYRON 11-10
15\BYRON 11-10-15 044.JPG

Image ID 116938
Image Date 11/10/2015



C:\Users\wkst-44\Pictures\2015-11-10 BYRON 11-10
15\BYRON 11-10-15 045.JPG

Image ID 116939
Image Date 11/10/2015



C:\Users\wkst-44\Pictures\2015-11-10 BYRON 11-10
15\BYRON 11-10-15 046.JPG

Image ID 116940
Image Date 11/10/2015



C:\Users\wkst-44\Pictures\2015-11-10 BYRON 11-10
15\BYRON 11-10-15 047.JPG



Creek

Data provided by JaNell Enlow County Assessor

Property Information - Date 06/26/2022

Attached Images

Image ID 116941
Image Date 11/10/2015



C:\Users\wkst-44\Pictures\2015-11-10 BYRON 11-10
15\BYRON 11-10-15 048.JPG

Image ID 116942
Image Date 11/10/2015



C:\Users\wkst-44\Pictures\2015-11-10 BYRON 11-10
15\BYRON 11-10-15 049.JPG

Image ID 116943
Image Date 11/10/2015



C:\Users\wkst-44\Pictures\2015-11-10 BYRON 11-10
15\BYRON 11-10-15 050.JPG

Image ID 116944
Image Date 11/10/2015



C:\Users\wkst-44\Pictures\2015-11-10 BYRON 11-10
15\BYRON 11-10-15 051.JPG



Creek

Data provided by JaNell Enlow County Assessor

Property Information - Date 06/26/2022

Attached Images

Image ID 116945
Image Date 11/10/2015



C:\Users\wkst-44\Pictures\2015-11-10 BYRON 11-10
15\BYRON 11-10-15 052.JPG

Image ID 116946
Image Date 11/10/2015



C:\Users\wkst-44\Pictures\2015-11-10 BYRON 11-10
15\BYRON 11-10-15 053.JPG

Image ID 116947
Image Date 11/10/2015



C:\Users\wkst-44\Pictures\2015-11-10 BYRON 11-10
15\BYRON 11-10-15 054.JPG

Image ID 116948
Image Date 11/10/2015



C:\Users\wkst-44\Pictures\2015-11-10 BYRON 11-10
15\BYRON 11-10-15 055.JPG



Creek

Data provided by JaNell Enlow County Assessor

Property Information - Date 06/26/2022

Attached Images

Image ID 116949
Image Date 11/10/2015



C:\Users\wkst-44\Pictures\2015-11-10 BYRON 11-10
15\BYRON 11-10-15 056.JPG

Image ID 116950
Image Date 11/10/2015



C:\Users\wkst-44\Pictures\2015-11-10 BYRON 11-10
15\BYRON 11-10-15 057.JPG

Image ID 116951
Image Date 11/10/2015



C:\Users\wkst-44\Pictures\2015-11-10 BYRON 11-10
15\BYRON 11-10-15 058.JPG

Image ID 116952
Image Date 11/10/2015



C:\Users\wkst-44\Pictures\2015-11-10 BYRON 11-10
15\BYRON 11-10-15 059.JPG



Creek

Data provided by JaNell Enlow County Assessor

Property Information - Date 06/26/2022

Attached Images

Image ID 116953
Image Date 11/10/2015



C:\Users\wkst-44\Pictures\2015-11-10 BYRON 11-10
15\BYRON 11-10-15 060.JPG

Image ID 116954
Image Date 11/10/2015



C:\Users\wkst-44\Pictures\2015-11-10 BYRON 11-10
15\BYRON 11-10-15 061.JPG

Image ID 116955
Image Date 11/10/2015



C:\Users\wkst-44\Pictures\2015-11-10 BYRON 11-10
15\BYRON 11-10-15 062.JPG

Image ID 116956
Image Date 11/10/2015



C:\Users\wkst-44\Pictures\2015-11-10 BYRON 11-10
15\BYRON 11-10-15 063.JPG



Creek

Data provided by JaNell Enlow County Assessor

Property Information - Date 06/26/2022

Attached Images

Image ID 116957
Image Date 11/10/2015



C:\Users\wkst-44\Pictures\2015-11-10 BYRON 11-10
15\BYRON 11-10-15 064.JPG

Image ID 116958
Image Date 11/10/2015



C:\Users\wkst-44\Pictures\2015-11-10 BYRON 11-10
15\BYRON 11-10-15 065.JPG

Image ID 116959
Image Date 11/10/2015



C:\Users\wkst-44\Pictures\2015-11-10 BYRON 11-10
15\BYRON 11-10-15 066.JPG

Image ID 116960
Image Date 11/10/2015



C:\Users\wkst-44\Pictures\2015-11-10 BYRON 11-10
15\BYRON 11-10-15 067.JPG



Creek

Data provided by JaNell Enlow County Assessor

Property Information - Date 06/26/2022

Attached Images

Image ID 116961
Image Date 11/10/2015



C:\Users\wkst-44\Pictures\2015-11-10 BYRON 11-10
15\BYRON 11-10-15 068.JPG

Image ID 116962
Image Date 11/10/2015



C:\Users\wkst-44\Pictures\2015-11-10 BYRON 11-10
15\BYRON 11-10-15 069.JPG

Image ID 116963
Image Date 11/10/2015



C:\Users\wkst-44\Pictures\2015-11-10 BYRON 11-10
15\BYRON 11-10-15 070.JPG

Image ID 114749
Image Date 9/17/2015

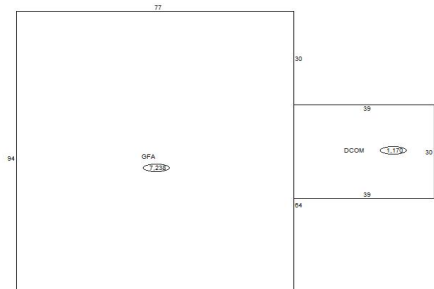

Sketch Image. Saved : 09/18/2015 04:36:11P



Creek

Data provided by JaNell Enlow County Assessor

Property Information - Date 06/26/2022

Attached Images

Image ID 114750
Image Date 9/17/2015

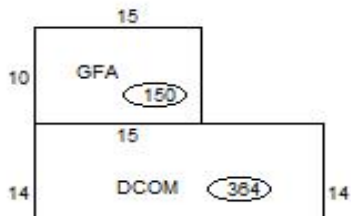

Sketch Image. Saved : 09/18/2015 04:38:48P

Image ID 89184
Image Date 2/25/2013

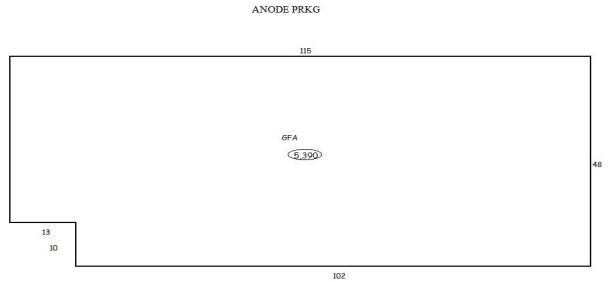

Sketch Image. Saved : 06/05/2021 10:57:03A

Image ID 89192
Image Date 2/25/2013

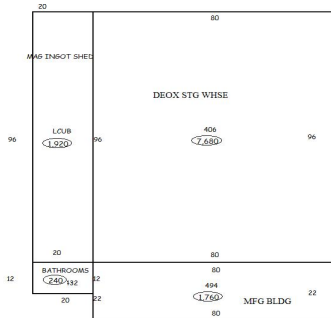

Sketch Image. Saved : 06/05/2021 10:57:04A

Image ID 89193
Image Date 2/25/2013

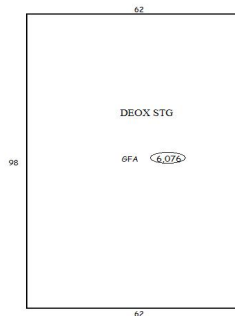

Sketch Image. Saved : 06/05/2021 10:57:05A



Creek

Data provided by JaNell Enlow County Assessor

Property Information - Date 06/26/2022

Attached Images

Image ID 89195
Image Date 2/25/2013

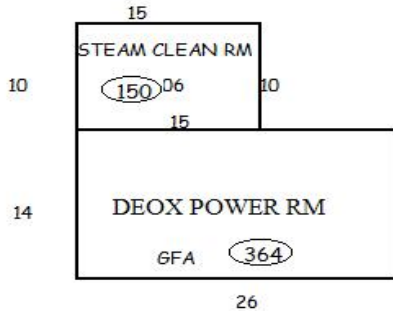

Sketch Image. Saved : 06/05/2021 10:57:06A

Image ID 89202
Image Date 2/25/2013

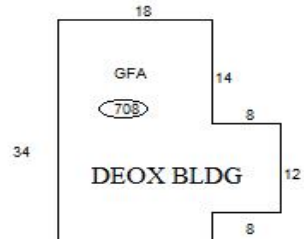

Sketch Image. Saved : 09/18/2015 04:39:19P

Image ID 89160
Image Date 2/22/2013

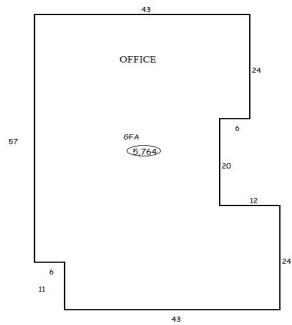

Sketch Image. Saved : 06/05/2021 10:30:52A

Image ID 89170
Image Date 2/22/2013

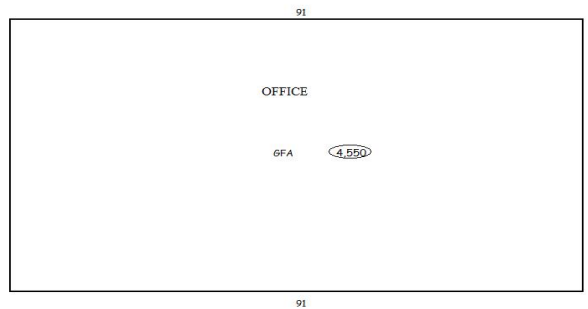

Sketch Image. Saved : 06/05/2021 10:30:52A



Creek

Data provided by JaNell Enlow County Assessor

Property Information - Date 06/26/2022

Attached Images

Image ID 89173
Image Date 2/22/2013

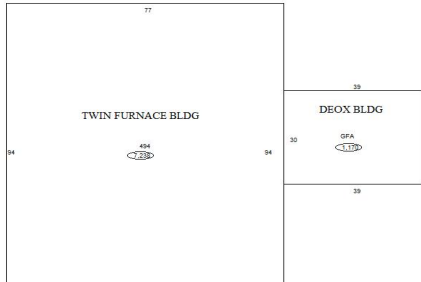

Sketch Image. Saved : 09/18/2015 04:35:00P

Image ID 89174
Image Date 2/22/2013

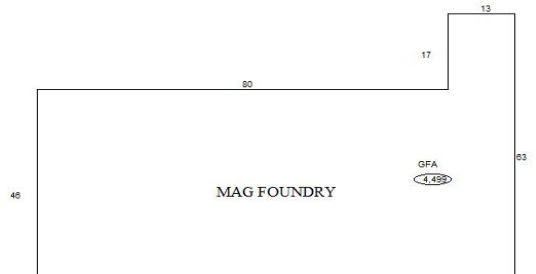

Sketch Image. Saved : 09/18/2015 04:35:14P

Image ID 89175
Image Date 2/22/2013

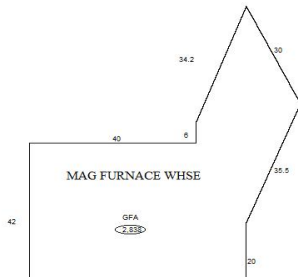

Sketch Image. Saved : 09/18/2015 04:35:33P

Image ID 89176
Image Date 2/22/2013

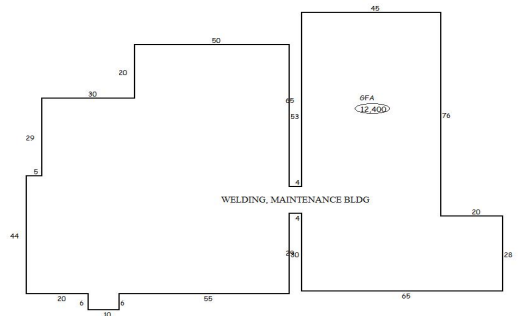

Sketch Image. Saved : 06/05/2021 10:57:01A



Creek

Data provided by JaNell Enlow County Assessor

Property Information - Date 06/26/2022

Attached Images

Image ID 89182
Image Date 2/22/2013

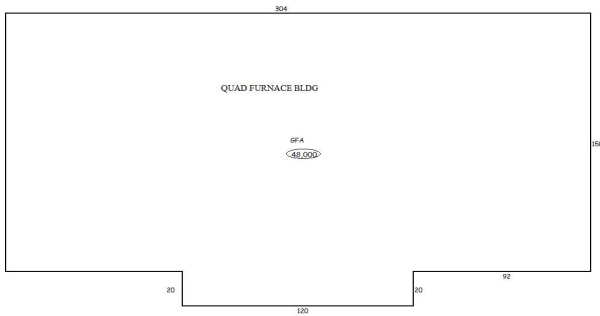

Sketch Image. Saved : 06/05/2021 10:57:02A

Image ID 89183
Image Date 2/22/2013

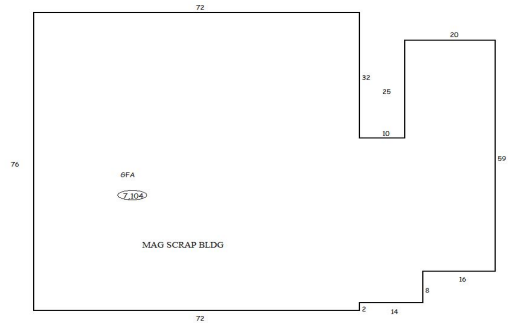

Sketch Image. Saved : 06/05/2021 10:57:03A

Image ID 32757
Image Date 10/13/2012



pictures\0000-26-018-011-0-037-00-MAINTBLDG&LAB.JPG

Image ID 32758
Image Date 10/13/2012



pictures\0000-26-018-011-0-037-00-BREAKRM.JPG



Creek

Data provided by JaNell Enlow County Assessor

Property Information - Date 06/26/2022

Attached Images

Image ID 32759
Image Date 10/13/2012



\\pictures\0000-26-018-011-0-037-00-01.JPG

Image ID 32760
Image Date 10/13/2012



\\pictures\0000-26-018-011-0-037-00-MAINTBLDG.JPG

Image ID 32763
Image Date 10/13/2012



\\pictures\0000-26-018-011-0-037-00-SHIPPING&REC.JPG

Image ID 32764
Image Date 10/13/2012



\\pictures\0000-26-018-011-0-037-00-QUADBLDG.JPG



Creek

Data provided by JaNell Enlow County Assessor

Property Information - Date 06/26/2022

Attached Images

Image ID 32765
Image Date 10/13/2012



\\pictures\0000-26-018-011-0-037-00-TRAINING&SHIPPING3
JPG

Image ID 32767
Image Date 10/13/2012



\\pictures\0000-26-018-011-0-037-00-MTLAWN.JPG

Image ID 32768
Image Date 10/13/2012



\\pictures\0000-26-018-011-0-037-00-CBLKELECBLDG.JPG

Image ID 32769
Image Date 10/13/2012



\\pictures\0000-26-018-011-0-037-00
SCRAPBIN&UNKNOWNBLDG.JPG



Creek

Data provided by JaNell Enlow County Assessor

Property Information - Date 06/26/2022

Attached Images

Image ID 32770
Image Date 10/13/2012



\\pictures\0000-26-018-011-0-037-00-DEOXSTGBLDG.JPG

Image ID 32771
Image Date 10/13/2012



\\pictures\0000-26-018-011-0-037-00-OFFICES.JPG

Image ID 32772
Image Date 10/13/2012



\\pictures\0000-26-018-011-0-037-00-MAGFOUNDRY.JPG

Image ID 32774
Image Date 10/13/2012



\\pictures\0000-26-018-011-0-037-00-MAGFOUNDRY(STG).JPG



Creek

Data provided by JaNell Enlow County Assessor

Property Information - Date 06/26/2022

Attached Images

Image ID 32775
Image Date 10/13/2012



\\pictures\0000-26-018-011-0-037-00-08.JPG

Image ID 32776
Image Date 10/13/2012



\\pictures\0000-26-018-011-0-037-00-TWINBLDG.JPG

Image ID 32777
Image Date 10/13/2012



\\pictures\0000-26-018-011-0-037-00-02.JPG

Image ID 32778
Image Date 10/13/2012



\\pictures\0000-26-018-011-0-037-00-OFFICE.JPG



Creek

Data provided by JaNell Enlow County Assessor

Property Information - Date 06/26/2022

Attached Images

Image ID 32779
Image Date 10/13/2012



\\pictures\0000-26-018-011-0-037-00-MAINTBLDG2.JPG

Image ID 32780
Image Date 10/13/2012



\\pictures\0000-26-018-011-0-037-00-TRAINING&SHIPPING
JPG

Image ID 32781
Image Date 10/13/2012



\\pictures\0000-26-018-011-0-037-00-06.JPG

Image ID 32782
Image Date 10/13/2012



\\pictures\0000-26-018-011-0-037-00-TRAINING2.JPG



Creek

Data provided by JaNell Enlow County Assessor

Property Information - Date 06/26/2022

Attached Images

Image ID 32783
Image Date 10/13/2012



\\pictures\0000-26-018-011-0-037-00-04.JPG

Image ID 32784
Image Date 10/13/2012



\\pictures\0000-26-018-011-0-037-00-SCRAPBINS.JPG

Image ID 32787
Image Date 10/13/2012



\\pictures\0000-26-018-011-0-037-00-DEOXBLDG.JPG